



For more than 25 years, the Vertical Contact Toaster has been a staple in foodservice operations, building a reputation for quality and reliability around the world.

The Vertical Contact Toaster gives buns a consistent, golden brown finish which helps the sandwich stay firm and delicious. The VCT-25 has a preset toast time of 25 seconds.



VCT-25 Vertical Contact Toaster



Dual-Sided Platen

Vertical Contact Toaster has more capacity than conventional single-sided toasters, allowing operators to quickly serve fresh products



Dial Temperature thermostat

Easily adjust the quality of the toast for a variety of different bread products.



Small Footprint

The upright design saves valuable counterspace, allowing it to easily integrate into any operation.

Vertical Contact Toaster | VCT-25

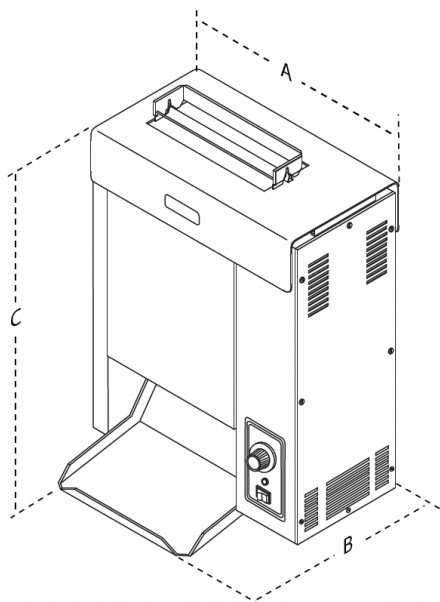

Features:

- Continuously moving conveyor allows for immediate toasting.
- Separate compression adjustments for heel and crown.
- Release sheets allow buns to move easily down the heated platen without sticking or slipping.
- Easy to operate and clean.
- Stainless steel construction.

VCT-25		Electrical Ratings			Dimensions						
Model & Mfg. No.	Capacity*	Approvals	Plug	Volts	Watts	Amps	Hz.	Width (A)	Depth (B)	Height (C)	Shipping Weight
VCT-25 9200620	25-sec. toast time		NEMA 5-15P	120	1760	14.7	50/60	21 1/4" (540 mm)	15 1/4" (387 mm)	23 1/4" (591 mm)	76 lbs. (34.5 kg)
VCT-25 9200626	25-sec. toast time		NEMA 6-20P	208-240	2600-3460	12.5-14.4	50/60	21 1/4" (540 mm)	15 1/4" (387 mm)	23 1/4" (591 mm)	76 lbs. (34.5 kg)
VCT-25 9200628	25-sec. toast time		CEE 7/7	208-240	2600-3460	12.5-14.4	50/60	22 1/4" (565 mm)	15 1/4" (387 mm)	23 1/4" (591 mm)	88 lbs. (39.9 kg)
VCT-25 9200637	25-sec. toast time		IEC-309	208-240	2600-3460	12.5-14.4	50/60	22 1/4" (565 mm)	15 1/4" (387 mm)	23 1/4" (591 mm)	88 lbs. (39.9 kg)
VCT-25 9200640	25-sec. toast time		CEE 7/7	230	1980	8.6	50/60	22 1/4" (565 mm)	15 1/4" (387 mm)	23 1/4" (591 mm)	88 lbs. (39.9 kg)
VCT-25 9200648	25-sec. toast time		BS-1363	230	1980	8.6	50/60	22 1/4" (565 mm)	15 1/4" (387 mm)	23 1/4" (591 mm)	88 lbs. (39.9 kg)

Dimensions are for item without shipping box. Shipping weight includes item and shipping box. Items highlighted in blue are for international markets.

VCT-25 (with belt wraps)

VCT-25 9200639	25-sec. toast time		CEE 7/7	208-230	1980	8.6	50/60	22 1/4" (565 mm)	15 1/4" (387 mm)	24 1/4" (616 mm)	82 lbs. (37.2 kg)
----------------	--------------------	--	---------	---------	------	-----	-------	------------------	------------------	------------------	-------------------

***Toast time will vary 20% depending on power frequency**

Bun Specifications

Crowns			Heels		
Feeder Opening	Min.	Max.	Feeder Opening	Min.	Max.
1 1/4" (32mm)	1/2" (13 mm)	7/8" (22 mm)	1 1/4" (32 mm)	1/2" (13 mm)	7/8" (22 mm)